



# PRODUCT SPECIFICATION

Product Name: Coin-type Supercapacitor

Product Model: HESC5R5224Z-V(Z011)

Prepared by: Lilingdong

Checked by: Wd Jing

Approved by: Wang Yong

## CUSTOMER APPROVED:

Customer Confirmation:

APPROVAL SIGNET:

DATE:

List



Quality Statement.....	4
1. Scope.....	5
2. Standard Testing Condition.....	5
3. General Characteristics.....	5
4. Packaging.....	5
5. Environmental Characteristics.....	6
6. Product Dimensions.....	6
7. Part Number system.....	7
8. The Measurement Methods.....	7
9. Handling Precautions and Guidelines.....	9
10. Products Disclaimer.....	11



## Modified List

Revision	Approved by	Modified content	Effective date
R1.1	LiLingdong	1、 The company name was changed from Shandong Goldencell Electronic Technology Co., Ltd. to Shandong Goldencell Energy Technology Co., Ltd. 2、 increased Maximum peak current(1s); 3、 Revised the product schematic; 4、 Updated the company headquarters and European branch address information.	2021.07.01



## Quality Statement

Proper use and maintenance will ensure that the supercapacitor will operate reliably and consistently for long periods of time.

After receiving the product, please check if the packaging is in good condition. If the packing is broken, it may cause damage to the product. If there is any damage, please contact our after-sales or sales staff within five working days.

Anyone who does not use or maintain the supercapacitor according to the manual shall be deemed to give up the warranty right. Shandong Goldencell Energy Technology Co., Ltd. and its service station have the right to no longer guarantee the warranty, and will not compensate for any losses arising from it. However, the corresponding paid service can be provided according to the situation.

Please reply and confirm us within seven working days after receiving your product and specific ation. We will regard that you agree with the product and the specification meets your requirem ents if you do not reply within seven working days.

### Headquarter

Add: No.X6699,Guangming Road,high tech Zone, Zaozhuang City,  
Shandong Province, China

Tel: +86-632-5199698

Fax: +86-632-5199218

Postcode: 277800

Email: [service@goldencell.biz](mailto:service@goldencell.biz)

Service Hotline: 400-812-5699

Web site: [www.goldencellbattery.com](http://www.goldencellbattery.com)

### Branch Office (Shenzhen)

Room 8006, Building 1, Shenzhen Beihang Building, Yuexing 4th Road,  
Nanshan District, Shenzhen, Guangdong, China

Tel: +86-755-28891995

Fax: +86-755-28892486

Postcode: 518057

### Branch Office (Europe)

Pihatörmä 1 A, 02240 Espoo, Finland

Tel: +358453246642

Email: [tony.yang@goldencell.biz](mailto:tony.yang@goldencell.biz)



### 1. Scope

This product specification describes the characteristics of Coin-type supercapacitor produced by Shandong Goldencell Energy Technology Co., Ltd..

### 2. Standard Testing Condition

All test and measurements shall be made under standard atmospheric conditions(Temperature: 15~35°C, Relative humidity: 25%~75%)for testing. Before the measurements are made, the supercapacitor shall be store at the measuring temperature for a time sufficient to allow the entire supercapacitor to reach this temperature. All tests of the specification book were carried out under the following environmental conditions:

Temperature: 25±2 °C Humidity:(60±15)%RH Air pressure: standard atmospheric pressure

### 3. General Characteristics

Item		Specification	
1	Model	HESC5R5224Z-V(Z011)	
2	Rated discharge capacitance	0.22 F	
3	Capacitance tolerance	-20 % ~ + 80 %	
4	Rated voltage	5.5 V	
5	Surge voltage	6.0 V	
6	Nominal impedance	AC Imp	50 Ω
		DC Imp	75 Ω
7	Weight	1.4 ± 0.05 g	
8	Maximum peak current(1s)	34 mA	
9	Leakage current (24 h)	≤ 0.005 mA	
10	Working temperature range	-40 ~ 70 °C	
11	Storage temperature range	-40 ~ 85 °C	
12	Cycle life	25°C, rated voltage-half rated voltage >500000 cycles,  ΔC/C ≤30%, ESR≤ 4 times of specified ESR	

### 4. Packaging

Model	Quantity(PCS)			Size of Packaging (L×W×H, mm)		Weight (Kg)
	Tray	Inner box	Box	Inner box	Box	
HESC5R5224Z-V(Z011)	150	3000	12000	331×228×117	485×355×265	22±1

### 5. Environmental Characteristics

Item		Specification/Condition
1	Temperature characteristics	$ \Delta C/C  \leq 30\%$ , $ESR \leq$ specified $ESR(25^\circ C)$ at $+70^\circ C$ $ \Delta C/C  \leq 50\%$ , $ESR \leq 4$ times of specified $ESR(25^\circ C)$ at $-25^\circ C$
2	High temperature load	$ \Delta C/C  \leq 30\%$ , $ESR \leq 4$ times of specified $ESR(25^\circ C)$ at $+70 \pm 2^\circ C$ /1000hrs/rated voltage
3	High temperature storage	$ \Delta C/C  \leq 30\%$ , $ESR \leq 2$ times of specified $ESR(25^\circ C)$ at $+70 \pm 2^\circ C$ /1000hrs/standby after fully charge
4	Humidity Resistance	$+40 \pm 2^\circ C$ , 90--95%RH, 240h, $ \Delta C/C  \leq 30\%$ , $ESR \leq 4$ times of specified $ESR(25^\circ C)$

### 6. Product Dimensions

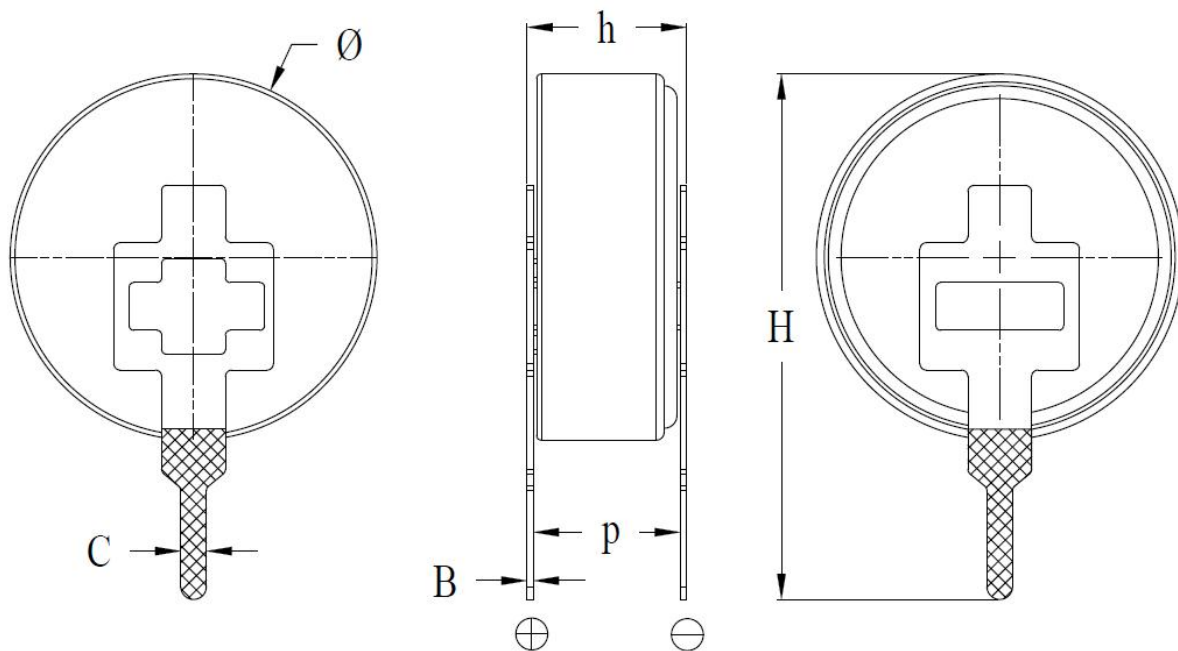

Item	Criteria	Item	Criteria
Φ	$11.5 \pm 0.5$ mm	H	$16.5 \pm 0.5$ mm
h	$5.0 \pm 0.5$ mm	P	$5.0 \pm 0.5$ mm
B	$0.20 \pm 0.05$ mm	C	$0.8 \pm 0.1$ mm

### 7. Part Number system

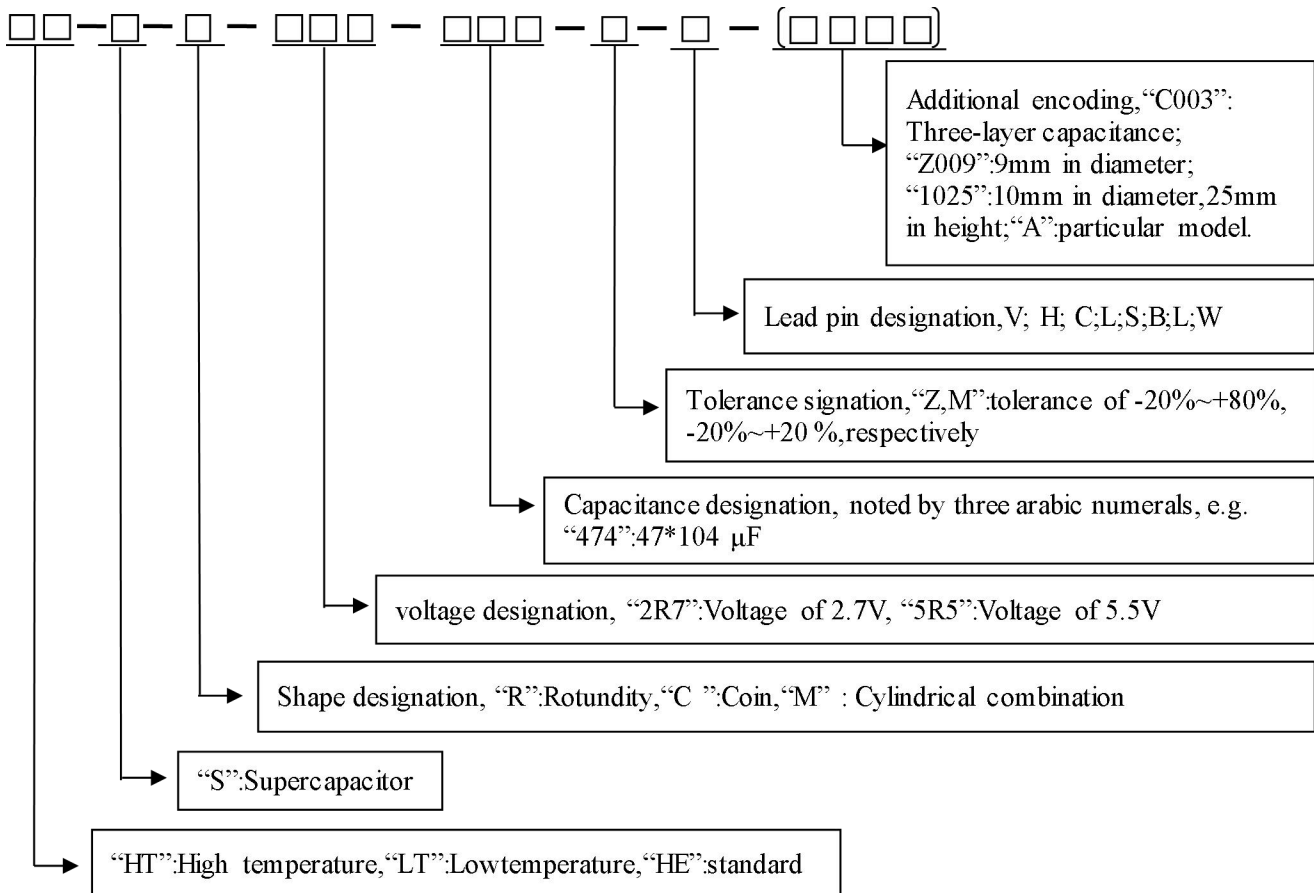

### 8. The Measurement Methods

#### 8.1 Capacitance (Constant current discharge method)

- (1) Turn the switch S to the DC power supply, charge the supercapacitor with constant current(general 5 mA) to rated voltage( $U_R$ );
- (2) Constant voltage charge at rated voltage( $U_R$ ) for 30min;
- (3) Discharge the supercapacitor with constant current(general 5 mA) to 0.1V.

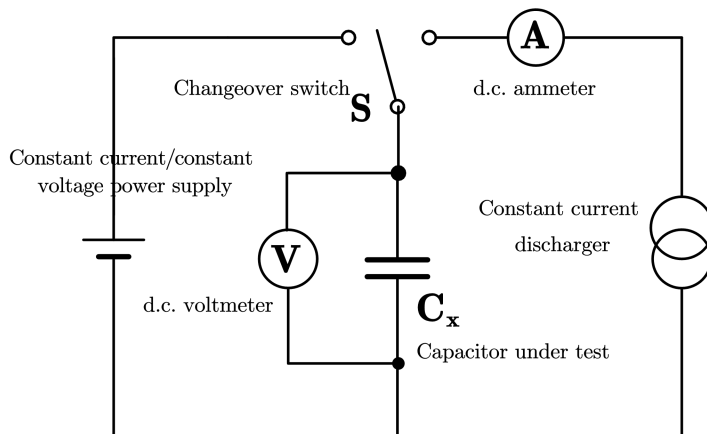

Figure1. Circuit for constant current discharge method

Measure the time  $t_1$  to  $t_2$  where the voltage between capacitor terminals at the time of discharge reduces from  $U_1$  to  $U_2$  as shown figure2. and calculate the capacitance value by the following formula:

$$C = \frac{I(t_2 - t_1)}{U_1 - U_2}$$

[ $C$ : is the capacitance(F);  $I$ : is the discharge current(A);

$t_1$ : is the time from discharge start to reach  $U_1$ (s);

$t_2$ : is the time from discharge start to reach  $U_2$ (s);

$U_1$ : is the measurement starting voltage(V);

$U_2$ : is the measurement end voltage(V).]

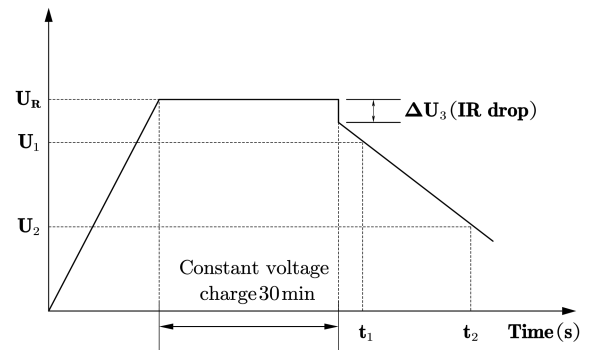

Figure2. Curve for charge-discharge

## 8.2 Internal resistance

**8.2.1 DC resistance method:**  $R_{DC} = \frac{U_3}{I}$

[ $R_{DC}$ : is the DC internal resistance( $\Omega$ );

$U_3$ : is the drop voltage for 10ms(V);

$I$ : is the discharge current(A).]

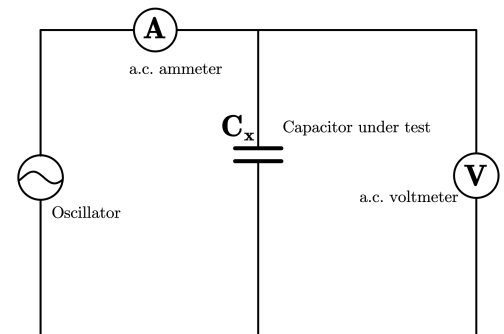

Figure3. Circuit for AC internal resistance method

### 8.2.2 AC resistance method

Measure AC internal resistance by the LCR meter (Frequency: 1kHz).

The internal resistance  $R_{AC}$  of a supercapacitor shall be calculated by the following formula:  $R_{AC} = \frac{U}{I}$

[ $R_{AC}$ : is the AC internal resistance( $\Omega$ );  $U$ : is the effective value of AC voltage(V r.m.s);  $I$ : is the effective value of AC current(A r.m.s).]

## 8.3 Leakage current

(1) Before this measurement is made, the capacitors shall be fully discharge. Discharge procedure shall take more than 1h;

(2) Apply rated voltage to the supercapacitor;

(3) Measure  $U_V$  after 0.5h, 1h, 2h, 24h, 48h and 72h. Calculator current

using the following formula:  $LC = \frac{U_v}{R} \times 10^3 mA$

[ $LC$ : is the Leakage current(mA);

$U_v$ : is the voltage between capacitor terminals(V);

$R$ : is the protective resistor of 1000 $\Omega$  or less( $\Omega$ ).]

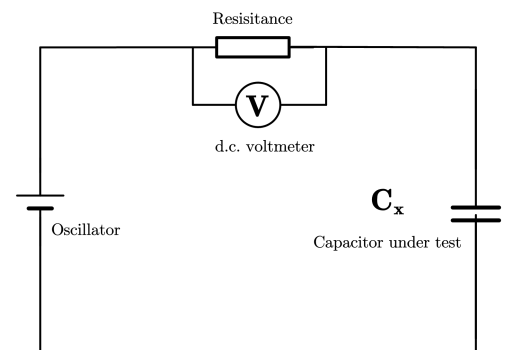

Figure4. Circuit for leakage current method



## 9. Handling Precautions and Guidelines

For safety application, please contact Shandong Goldencell Energy Technology Co., Ltd. directly for any technical specifications, handling precautions and guidelines critical to application.

### 9.1 Polarity and voltage of supercapacitor

(1) Supercapacitor have polarities

Do not apply a reverse or AC voltage. If a reversed voltage is applied to a capacitor for a long period of time, then its life will be reduced and critical failures such as electrolyte leakage may occur.

(2) Do not apply an over-voltage (a voltage exceeding the rated voltage )

If voltage exceeding the rating is applied to the capacitor for a long time, then its life will be reduced and critical failures such as electrolyte leakage or physical damage due to gas generated by electrochemical reaction or explosion may occur.

### 9.2 Circuits through which ripple currents pass

When using a supercapacitor in a circuit through which ripple currents pass, monitor the allowable temperature rang. The internal resistance of electric supercapacitors is higher than that of electrolytic capacitors. Supercapacitors may generate heat due to ripple currents.

### 9.3 Effect of ambient temperature on the supercapacitor

Supercapacitor life is affected by usage temperatures. Generally speaking, supercapacitor life is approximately doubled when the temperature is decreased by 10°C. Therefore, lower the usage temperature as much as possible. Using supercapacitors beyond the guaranteed range may cause rapid deterioration of their characteristics and cause them to break down. The temperature referred to here includes the ambient temperature within the equipment, the heat produced by heat generating devices(power transistor, resistors, etc.), self-heating due to ripple currents, etc. Take all of these factors into consideration when checking the supercapacitor's temperature. Do not place any heat generating devices on the back of the supercapacitor.

### 9.4 Voltage drop

Pay particular attention to the instantaneous working current and voltage drop due to the supercapacitor's internal resistance when used in backup mode. The discharging current level is different depending on the supercapacitor's internal resistance.

### 9.5 Series connection

When connecting supercapacitors in series, add a bleeder resistor in parallel with each supercapacitor by taking the leak current into consideration so that the balanced of voltages is not disrupted.

### 9.6 Solder of supercapacitor

When soldering a supercapacitor to a printed circuit board, excessive heat stress could cause the deterioration of the supercapacitor's electrical characteristics. For example, the integrity of the seal can be compromised causing the electrolyte to leak, and short circuits could occur in addition to failure of appearance.

Please observe the following guidelines:

(1) Manual soldering

Do not touch the supercapacitor body with a soldering iron. Solder the capacitor using a soldering tip temperature of 350°C or less for 4 seconds or less. Solder the capacitor three times or less at intervals of 15 seconds or more.

(2) Folw soldering

(a) Do not dip the body of the supercapacitors into a soldering bath.

(b) Keep the supercapacitor's surface temperature at or below 100°C for no more than 60 seconds(the peak 105°C) when soldering. Please refer to the chart at right to set soldering conditons.It is recommended to check the supercapacitor temperature before you use.

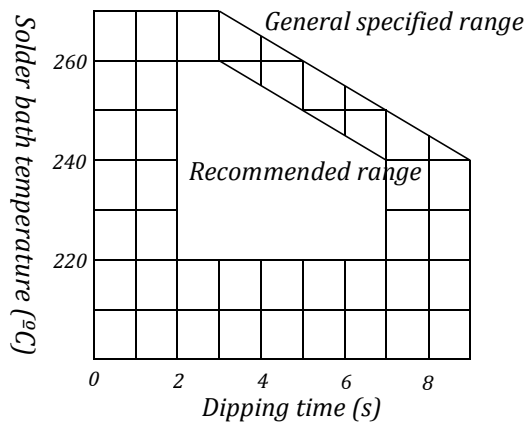

*[Pre-heating temperature: 110°C or under (on the surface or circuit board); 100°C or under(on the surface of supercapacitor); Pre-heating time: 60 seconds or under; Board thickness: 0.8mm or more.]*

(c) Other heat stress

Keep the supercapacitor's surface temperature at or below 100°C for no more than 60 seconds(the peak 105°C) when applying heat to bake the PCB or fixing resin, etc. The supercapacitor voltage must be 0.3V or less.

Do not use a supercapacitor more than once after it has been mounted on the PCB. Excessive heat stress is applied when deatching if from the PCB. Please observe (1) Manual soldering when adjusting it.

Be sure that excessive heat stress is not applied to the supercapacitor when other parts in its surroundings are detached or adjusted.

(d) Others

The lead wires and terminals are tin-plating for solderability. Rasping lead wires or termianls may damage the tin-plating layer and degrade the solderability.

Do not apply a large mechanical force to the lead wires or terminals. Otherwise, they may break or come off or the supercapacitor characterisitcs may be damaged.

**9.7 Precautions for using equipment**

Aviod using mounting equipment in environments where:

(1) Supercapacitors are exposed to water, salt water or oil.

(2) Supercapacitors are exposed to direct sunlight.

(3) Supercapacitors are exposed to high-temperature and high-humidity where water can condense on the supercapacitor surface.

- (4) Supercapacitors are subject to various active gases.
- (5) Supercapacitors are exposed to acidic or alkaline environments.
- (6) Supercapacitors are subject to high-frequency induction.
- (7) Supercapacitors are subject to excessive vibrations or mechanical impact.

### 9.8 Emergency procedures

If the supercapacitors generate heat, then smoke may come out of the exterior resin. Under these conditions turn off the equipment immediately and stop using it.

Do not place your face or hands close to the supercapacitor, burns may be caused.

### 9.9 Storage of supercapacitor

Do not store supercapacitors in a high-temperature or high-humidity environment. Store supercapacitor at a room temperature of  $25\pm 10^{\circ}\text{C}$  and a relative humidity of 80% or less.

Store supercapacitors in their packaging as long as possible.

Avoid storing capacitors under the following conditions.

- (1) Exposed to water, high temperatures or humidity, or when condensation can occurs.
- (2) Exposed to oil or in environments filled with gaseous oil contents.
- (3) Exposed to salt water or environments filled with saline substances.
- (4) In environments filled with harmful gases(hydrogen disulfide, sulfurous acid, nitrous acid, chlorine, bromine, bromomethane, etc.)
- (5) In environments filled with harmful alkaline gases such as ammonia.
- (6) Exposed to acid or alkaline solvents.
- (7) Exposed to direct sunlight, ozone, ultraviolet or radial rays.
- (8) Exposed to vibrations or mechanical impact.

### 9.10 Discarding of supercapacitor

Dispose of supercapacitor as industrial waste. They are comprised of various metals and resin

## 10. Products Disclaimer

Before using the supercapacitor, please read the specifications, usage instruction and some attentions carefully. Shandong Goldencell Energy Technology Co., Ltd. is not responsible for the incident caused by not obeying the Manual. The phenomenon such as incorrect using method or wrong circuit connection, working index are inconsistent with the Manual, cause damage to product, over load and its accessories, we are not responsible for it. If the product performance is not changed, Products are subject to change without notice.

Shandong Goldencell Energy Technology Co., Ltd. has the right to change the content of specification without prior notice. The final explanation of specification belongs to Shandong Goldencell Energy Technology Co., Ltd..